



**LOGOTAYP**  
*LOGOTYPE*

Dairesel dünya formu, global pazarlarda etkin bir oyuncu olduğumuzu, ulusal ve uluslararası standartlardaki kaliteli üretimimizi temsil eder. Ortadaki e sembolü, Erse'nin "e" harfini ve kablunun dünyayı sardığını ifade eder. Daireyi saran bu kablo formu kırmızı ve gri renkleri buluşturarak B2B iş ortaklıklarını işaret eder, bu işaret el sıkışıp anlaşma sağlayan iki iş ortağı görünümündedir.

*The circular world form represents that we are an active player in global markets and our quality production in national and international standards. The e symbol in the middle indicates the letter "e" of Erse and the cable surrounds the earth. This cable form, which surrounds the circle, combines red and grey colours to indicate B2B business partnerships, this sign looks like two business partners shaking hands to agree.*

**Gri Renk**  
Sektördeki deneyimimizi,  
kurumsal bakış açımızı ve kaliteli  
hizmet anlayışımızı temsil eder.

*Grey Colour*

*This colour represents our experience in the sector, our corporate perspective and our understanding of quality service.*

**Kırmızı Renk**  
Dinamik ve güçlü kurumsal yapımızla  
beraber lider ruhumuzu temsil eder.

*Red Colour*

*This colour represents our leader spirit together with our dynamic and strong corporate structure.*

**Beyaz Renk**  
Kurumsal iletişimimizin merkezinde  
yer alan iç ve dış paydaşlarımızla  
aramızdaki dürüstlüğe dayanan  
güven duygusunu temsil eder.

*White Colour*

*This colour represents the sense of trust based on honesty with our internal and external stakeholders, which is at the center of our corporate communications.*



**erse**

# LOGO GÜVENLİK ALANI

LOGO SAFE AREA

Erse logotaypının etrafında bırakılması önerilen minimum alanlar (güvenlik alanı) aşağıda "x" ile gösterilen harflerin yüksekliği kadar olmalıdır.

*The safety area around the Erse logotype is suggested on all sides to be at least the height of the lowercase letters, marked below as "x".*

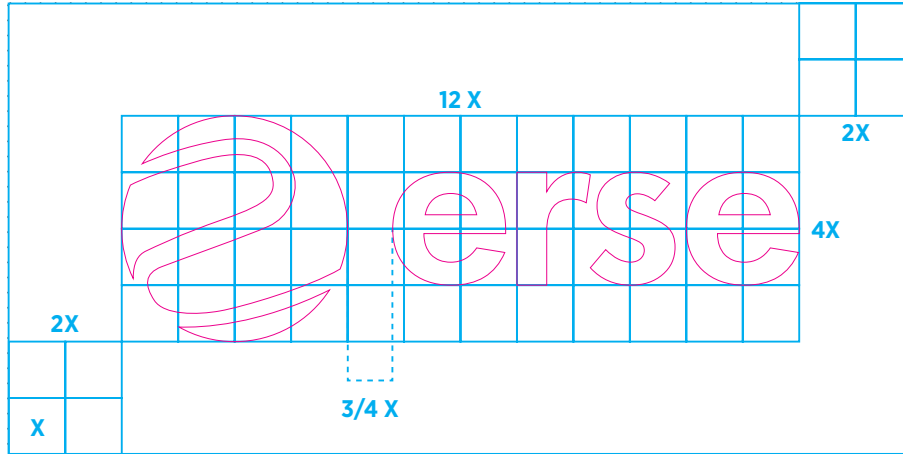

# LOGONUN MİNİMUM KULLANIM ÖLÇÜLERİ

MINIMUM DIMENSIONS OF THE LOGO

Erse logotaypının minimum kullanım  
ölçüsü 22 mm'dir.

*The minimum acceptable size of the  
erse logotype is 22 mm.*



# LOGONUN ZEMİNLİ UYGULAMALARI

LOGO APPLICATIONS ON BACKGROUNDS

Erse logotaypının net görünümü beyaz zemindedir. Uygulamalarda tercih edilmesi gereken zemin beyazdır. Beyaz zeminin olmadığı yerlerde aşağıdaki renk zeminleri kullanılabilir. Erse sembolünün renklerine göre bu zeminler dışında başka zeminler kullanılmamalıdır.

*The best view of the Erse logotype is on a white background. A white background is the preferred background in applications. The following color floors can be used where there is no white background. It should not be used on other floors other than these floors according to the colors of Erse symbol.*

Kırmızı Zemin

Red Background



Gri Zemin

Grey Background



Siyah Zemin

Black Background



# LOGONUN YANLIŞ KULLANIMLARI

INCORRECT USE OF THE LOGO

Erse logotayı herhangi bir nedenden dolayı kesinlikle deęiştirilmemeli ve deforme edilmemelidir.

*Erse logotype may not be altered at any time for any reason.*

DOĐRU



YANLIŞ



# LOGO VE SİMGELERİN RENK KULLANIMLARI

USE OF COLOR IN THE LOGO AND SYMBOLS

Kurumsal renkler, aşağıdaki renk standartlarına (Pantone, CMYK, RGB ve RAL) göre Erse logotayı renk kodlarında kullanılmalıdır.

*Corporate colors should be used in Erse logotype color codes according to the color standards below (Pantone, CMYK, RGB and RAL).*



**Pantone 186 C**  
CMYK 12, 100, 92, 2  
RGB 207, 32, 46



**Pantone Cool Gray 9C**  
CMYK 0, 0, 0, 65  
RGB 120, 120, 120



# LOGONUN GÖRSEL ÜZERİNDE KULLANIMLARI

USE OF THE LOGO ON IMAGES

Erse logotayı seçilen görselin üzerinde görülebilir uygun yerlerde gösterilmeli ve renklerin kullanımına dikkat edilmelidir.

*Erse logotype should be displayed in the appropriate place on the selected image and attention should be paid to the use of colours.*



Filigran, kağıt veya katalog gibi kurumsal kimlik materyallerinin belli bir kısmı kesilecek şekilde kullanılmalıdır.

Filigranın dokusal bütünlüğünün bozulmamasına çok fazla veya çok az kesilmemesine dikkat edilmelidir.

*Watermark should be used on corporate identity materials such as paper or catalogue, with a certain part of it being cut off.*

*The point to be considered is that the textural integrity of the watermark is not disturbed, it is not cut too much or too little.*

DOĞRU



YANLIŞ

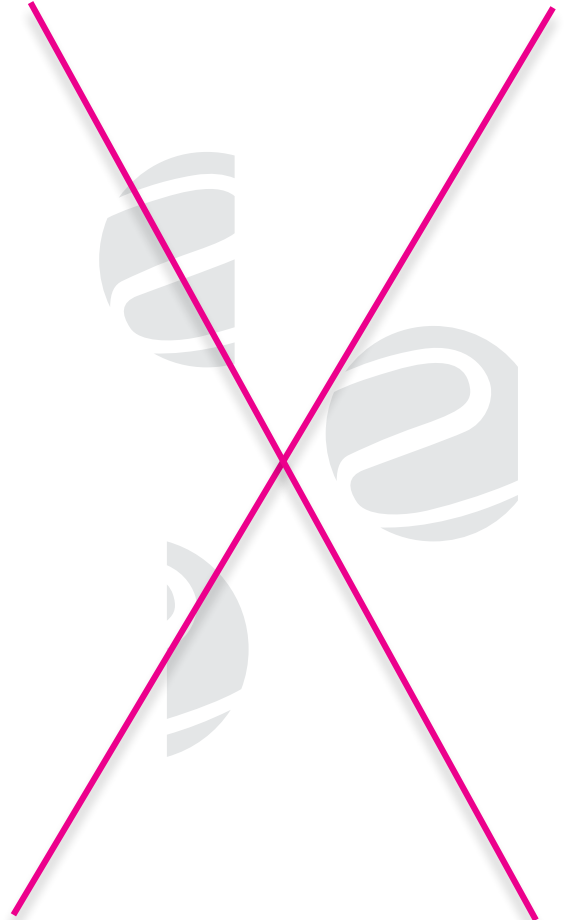

Gotham Font Ailesi, Erse Kablo'nun kurumsal yazı karakteridir. Erse logotaypında kullanılan bu yazı karakteri kurumsal iletişim faaliyet ve uygulama alanlarında her zaman birincil olarak kullanılmalıdır.

New York merkezli "Hoefler & Frere-Jones" tasarım ofisinin 2000 yılında tasarlamış olduğu "Gotham" font ailesi, maskülen olduğu kadar yeni, açık ve anlaşılır tasarım algısı ile Erse Kablo görsel kimliğinin kurumsal yapısını destekler.

Gotham, Gotham Narrow, Gotham XNarrow seçenekleriyle çok geniş bir font ailesine sahiptir. Her türlü alanda rahatlıkla kullanım kolaylığı sağlamaktadır.

Gotham ailesi aşağıda örneklendirilmiştir.

*Gotham Font Family is the corporate typeface of Erse Kablo. This font used in the Erse logotype should always be used primarily in corporate communication activities and application areas.*

*The "Gotham" font family, designed by the New York-based "Hoefler & Frere-Jones" design office in 2000, supports the corporate structure of Erse Kablo visual identity with its new, clear and understandable design perception as well as masculine.*

*Gotham has a very wide font family with Gotham Narrow, Gotham XNarrow options. It provides ease of use in all kinds of areas.*

*The type family of Gotham is shown below.*

Abc12

abcdefghijklmnoprsstuuvyz  
ABCDEFGHIĜHIJKLMNOÖPRSŞTUÜVYZ 0123456789,;?!%&@

Abc12

abcdefghijklmnoprsstuuvyz  
ABCDEFGHIĜHIJKLMNOÖPRSŞTUÜVYZ 0123456789,;?!%&@

Abc12

abcdefghijklmnoprsstuuvyz  
ABCDEFGHIĜHIJKLMNOÖPRSŞTUÜVYZ 0123456789,;?!%&@

Abc12

abcdefghijklmnoprsstuuvyz  
ABCDEFGHIĜHIJKLMNOÖPRSŞTUÜVYZ 0123456789,;?!%&@

Abc12

abcdefghijklmnoprsstuuvyz  
ABCDEFGHIĜHIJKLMNOÖPRSŞTUÜVYZ 0123456789,;?!%&@

Abc12

abcdefghijklmnoprsstuuvyz  
ABCDEFGHIĜHIJKLMNOÖPRSŞTUÜVYZ 0123456789,;?!%&@

Abc12

abcdefghijklmnoprsstuuvyz  
ABCDEFGHIĜHIJKLMNOÖPRSŞTUÜVYZ 0123456789,;?!%&@

Abc12

abcdefghijklmnoprsstuuvyz  
ABCDEFGHIĜHIJKLMNOÖPRSŞTUÜVYZ 0123456789,;?!%&@

Erse ürün markalarının logotayplarının etrafında bırakılması önerilen minimum alanlar (güvenlik alanı) aşağıda "x" ile gösterilen harflerin yüksekliği kadar olmalı ve eşit oranda kullanımı sağlanmalıdır.

*The minimum areas (safety area) recommended to be left around the logotypes of Erse product brands should be as high as the letters indicated by the "x" below and should be used equally.*



# MARKALAR

BRANDS

Erse ürün markalarının logotayplarının etrafında bırakılması önerilen minimum alanlar (güvenlik alanı) aşağıda "x" ile gösterilen harflerin yüksekliği kadar olmalı ve eşit oranda kullanımı sağlanmalıdır.

*The minimum areas (safety area) recommended to be left around the logotypes of Erse product brands should be as high as the letters indicated by the "x" below and should be used equally.*





ERSE KABLO SAN. & TİC. A.Ş.

**Merkez Ofis Head Office**

Halil Rifat Paşa Mh. Yüzer Havuz Sk. No: 5-9  
Şişli, İstanbul / Türkiye

**T.** +90 (212) 320 26 80 (pbx) **F.** +90 (212) 320 26 84

**Fabrika Factory**

Ortaköy Sanayi Bölgesi Elif Sk. No:12  
Silivri, İstanbul / Türkiye

**T.** +90 (212) 734 37 00 (pbx) **F.** +90 (212) 734 37 01

[f](#) [t](#) [i](#) [in](#) [You Tube](#) / [ersekablo](#)

[info@ersekablo.com.tr](mailto:info@ersekablo.com.tr)

[ersekablo.com.tr](http://ersekablo.com.tr)